

# Fact Sheet

## KH II 100 Pro

# BIZERBA

*Modern PC technology allowing you to be totally flexible is what the K-Class II Pro series stands for. Enjoy more performance due to a large RAM. All models are provided with a powerful Intel® Quad Core processor. Ideally suitable to implement new features or individual requirements. With their attractive design these solutions also ideally integrate in your shop concept from an optical point of view.*



**More informationen**  
High performance  
with a wide range of  
solutions and options.

Specifications	Facts	Details
<b>Variants</b>	KH II 100 Pro 7" KH II 100 Pro 7" B KH II 100 Pro 7" G KH II 100 Pro SB	With 7" customer display With 7" customer display, without weighing system With 7" customer display and separate load receptor Without customer display
<b>Color</b>	Anthracite gray Signal white	RAL 7016 RAL 9003
<b>Operator display</b>	12.1" touch TFT	Resolution: 800 x 600 Optionally in combination with RIK: 1,024 x 768 LED backlighting Resistive 5-wire touch technology Infinitely adjustable viewing angle
<b>Customer display</b>	7" TFT	Resolution: 800 x 480 LED backlighting Infinitely adjustable viewing angle
<b>Operating system</b>	Windows 10 IoT Enterprise 2016 LTSB  BizLPOS3 OpenSuse® ≥ 42.1 Leap Kernel 4.2	64 bit Windows  64 bit Linux
<b>Scale software</b>	RetailPowerScale  RetailIntegratorsKit (RIK)	Bizerba scale software, compatible with RetailFramework products  3rd-party software
<b>Processor</b>	Intel® Celeron® Processor N3160 Quad Core	Clock rate of up to 2.24 GHz L2 cache: 2 MB Instruction set: 64 bit Integrated graphics card: Intel® HD Graphics 400
<b>RAM</b>	DDR3L RAM	4 GB, optionally 8 GB
<b>Mass storage</b>	SSD	60 GB, optionally 120 GB
<b>Printer</b>	3" receipt/linerless printer 3" label printer  Dual printer 2" receipt + 2" linerless Dual printer 2" receipt + 3" label	Dual printer 2" receipt + 3" label Up to 3"/80 mm paper width, 200 dpi Print speed up to 150 mm/s, depending on the paper used  Optional dual printer
<b>Interfaces</b>	2 x USB 3.0 2 x USB 2.0 1 x COM LAN Audio output	Super speed High speed DSUB RJ45, GBit LAN 3.5 mm jack
<b>Weighing ranges</b>	3/6 kg 6/15 kg 15/30 kg	Interval 1/2 g, min. 20 g Interval 2/5 g, min. 40 g Interval 5/10 g, min. 100 g  Additional weighing ranges up to 150 kg thanks to connection of external load receptors: KH II 100 Pro G
<b>Temperature range</b>	-10 °C to +40 °C	Operating temperature

<b>Power consumption</b>	In stand-by 3.8 W During operation typically 26 W to 31 W	Energy saving thanks to use of Wake on LAN Depending on the version
<b>Net weight of device</b>	KH II 100 Pro	Approx. 18 kg
<b>Options</b>	<b>Facts</b>	<b>Details</b>
<b>Software extensions</b>	RetailApps  Software modules: Cash register, scanning, e-cash, inventory, delivery note, proof of origin, time registration, video journal, RetailConnect	Extra software function per RetailApps  Extra software functions per module
<b>Easy Level</b>	Tilt compensation	Automatic correction of incorrect weight values due to angled position of the scale
<b>WLAN modules</b>	BWLC  USB	Bizerba Wireless LAN Client 802.11 a/b/g max. 300 MBit/s  USB WLAN stick (no floating sales mode possible) 802.11 a/b/g/n max. 300 MBit/s
<b>Cash register drawer connection and 2nd COM</b>	Cash register drawer connection in combination with second COM interface: RS232	RJ12, max. 2 cash register drawers possible with an adapter

## Infographic



## Symbols



Java  
Powered

Linux  
64 bit

Windows 10

## Dimensions

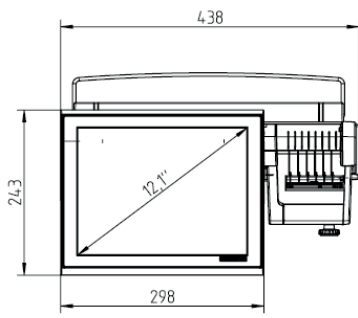

KH II 100 Pro 12.1" operator display

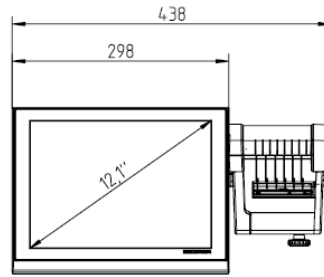

KH II 100 Pro B/G 12.1" operator display

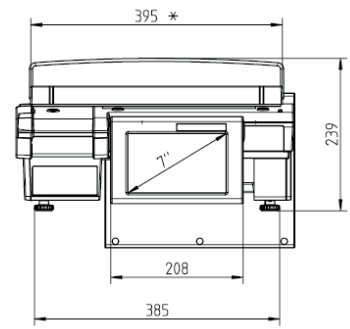

KH II 100 Pro 7" customer display

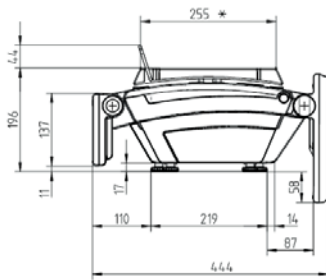

KH II 100 Pro 12.1" + 7"

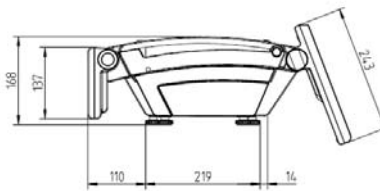

KH II 100 Pro B/G 12.1" + 7"

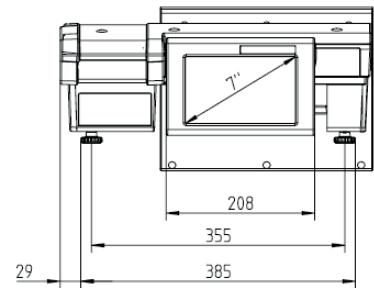

KH II 100 Pro B/G 7" customer display

**Bizerba SE & Co. KG**  
 Wilhelm-Kraut-Straße 65  
 72336 Balingen  
 Germany

T +49 7433 12-0  
 F +49 7433 12-2696  
 marketing@bizerba.com

[www.bizerba.com](http://www.bizerba.com)